



Computer Graphics Solutions

DATASHEET

DMAC
Version 1.02

Disclaimer

This document is written in good faith with the intend to assist the readers in the use of the product. Circuit diagrams and other information relating to Think Silicon Ltd products are included as a means of illustrating typical applications. Although the information has been checked and is believed to be accurate, no responsibility is assumed for inaccuracies. Information contains in this document is subject to continuous improvements and developments.

Think Silicon Ltd products are not designed, intended, authorized or warranted for use in any life support or other application where product failure could cause or contribute to personal injury or severe property damage. Any and all such uses without prior written approval of Think Silicon Ltd. will be fully at the risk of the customer.

Think Silicon Ltd. disclaims and excludes any and all warranties, including without limitation any and all implied warranties of merchantability, fitness for a particular purpose, title, and infringement and the like, and any and all warranties arising from any course or dealing or usage of trade.

This document may not be copied, reproduced, or transmitted to others in any manner. Nor may any use of information in this document be made, except for the specific purposes for which it is transmitted to the recipient, without the prior written consent of Think Silicon Ltd. This specification is subject to change at anytime without notice. Think Silicon Ltd. is not responsible for any errors contained herein.

In no event shall Think Silicon Ltd. be liable for any direct, indirect, incidental, special, punitive, or consequential damages; or for lost of data, profits, savings or revenues of any kind; regardless of the form of action, whether based on contract; tort; negligence of Think Silicon Ltd or others; strict liability; beach of warranty; or otherwise; whether or not any remedy of buyers is held to have failed of its essential purpose, and whether or not Think Silicon Ltd. has been advised of the possibility of such damages.

Copyright Notice

No part of this specification may be reproduced in any form or means, without the prior written consent of Think Silicon Ltd.

AMBA® is a registered trademark of ARM Limited.

AHB™ is a trademark of ARM Limited.

Questions or comments may be directed to:

Think Silicon Ltd
Suite B12
Patras Science Park
Rion Achaïas 26504
Greece

web: <http://www.think-silicon.com>
email: info@think-silicon.com
Tel: +30 2610 911543
Fax: +30 2610 911544

Document Revision History

Editor	Revision	Date	DESCRIPTION
GS	1.00	28/02/2008	Initial Version
MM	1.01	26/08/2008	Extra figures for channel configurations and register descriptions added
GS,TR	1.02	25/07/2011	Register set review, document format

1 Overview

The Think-Silicon DMAC is a web configurable generator for DMA Controller.

2 Features

- AMBA AHB 2.0 compliant
- Configurable DMA transfers
 - AHB to AHB
 - AHB to FIFO
 - FIFO to AHB
- Configurable number of channels
- Configurable FIFO size
- AMBA AHB Slave Interface for register programming
- AMBA AHB Master Interface(s) for DMA transfers
- FIFO access Interface(optional) for DMA transfers
- One FIFO per channel
- Different Clock Domains at FIFO Interface and AMBA AHB Bus Interface
- AMBA AHB Master supports burst transfers
- Byte alignment supported
- Direct Access to FIFO data
- Programmable Interrupt lines

3 Architecture

3.1 Block Diagram

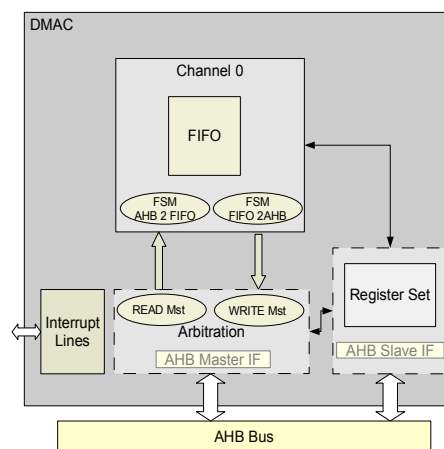

Figure 3-1 Single Channel AHB to AHB DMA transfers (common AHB Bus)

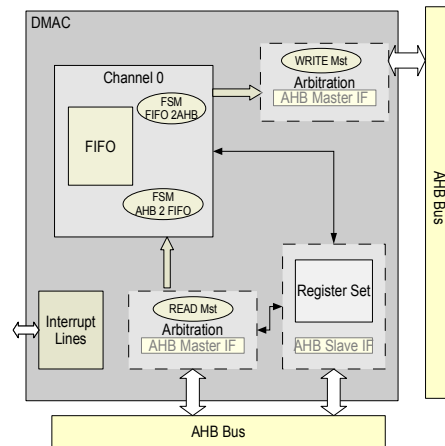

Figure 3-2 Single Channel AHB to AHB DMA transfers (separate AHB Buses)

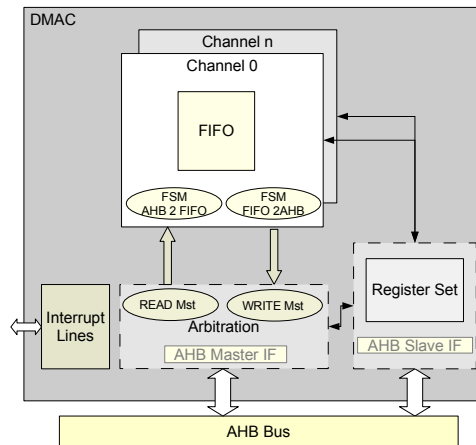

Figure 3-3 Multiple Channel AHB to AHB DMA transfers (common AHB Bus)

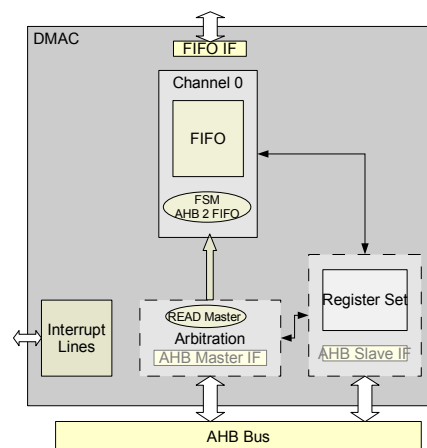

Figure 3-4 Single Channel AHB to FIFO DMA transfers

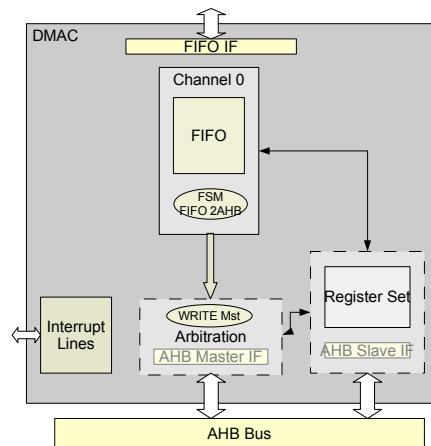

Figure 3-5 Single Channel FIFO to AHB DMA transfers

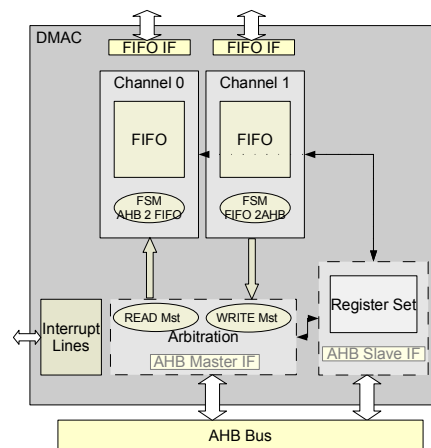

Figure 3-6 Multiple Channel AHB to FIFO, FIFO to AHB DMA transfers

3.2 Port Interface

Table 3-1 AHB Master Port list (Optional: second IF in case of different AHB Buses : Figure 3-2)

PORT	TYPE	DESCRIPTION
HCLK	Input	Bus Clock
HRESETn	Input	Bus Reset
HLOCK_mst	Output	Bus Lock
HBUSREQ_mst	Output	Bus Request
HGRANT_mst	Input	Bus Grant
HADDR_mst[31:0]	Output	Address Bus
HTRANS_mst[1:0]	Output	Transfer Type

PORT	TYPE	DESCRIPTION
HBURST_mst[2:0]	Output	Burst Type
HSIZE_mst[2:0]	Output	Transfer Size
HWRITE_mst	Output	Transfer Direction
HPROT_mst[3:0]	Output	Protection Control
HWDATA_mst[31:0]	Output	Write Data Bus
HRDATA_mst[31:0]	Input	Read Data Bus
HREADY_mst	Input	Transfer Done
HRESP_mst[[1:0]	Input	Transfer Response

Table 3-2 AHB Slave Port list

PORT	TYPE	DESCRIPTION
HTRANS_slv	Input	Transfer Type
HSEL_slv	Input	Peripheral selection signal
HSIZE_slv	Input	Transfer Size
HADDR_slv[31:0]	Output	Address Bus
HWDATA_slv[31:0]	Input	Write Data Bus
HRDATA_slv[31:0]	Output	Read Data Bus
HRESP_slv[[1:0]	Output	Transfer Response
HREADY_slv	Output	Transfer Done

Table 3-3 FIFO Interface Port list (Optional: One for every Channel that with FIFO IF)

PORT	TYPE	DESCRIPTION
Read_active	Input	Read Request
Read_size[1:0]	Input	Size (in bytes) of active read
Read_clk	Input	Read Clock
Ready_to_read	Output	FIFO is ready to read
Read_data[31:0]	Output	Data read from FIFO
Write_active	Input	Write Request
Write_size[1:0]	Input	Size (in bytes) of active write
Write_clk	Input	Write Clock
Ready_to_write	Output	FIFO is ready to be Written
Write_data[31:0]	Input	Write data to FIFO

Table 3-4 Miscellaneous ports

PORT	TYPE	DESCRIPTION
Irq	Output	Interrupt request
Endianness	Input	Endianness control: 0 Little Endiannes, 1: Big Endianness

4 Register Set

The following tables describe register set per channel for various DMAC configurations

Table 5-1 Register Set (Bus to Memory)

ADDRESS OFFSET	REGISTER		DESCRIPTION
0x00	Control	R/W	Bits 31..9: reserved Bit 8: Zero Latency:when set, FIFO read port operates without latency Bit 7: reserved Bit 6: discard fifo reset Bit 5: read fifo reset Bit 4: write fifo reset Bit 3: dma start Bit 2: fifo read empty flag Bit 1: fifo write full flag Bit 0: dma lock
0x04	fifo_wpointer	R/O	contains the value of actual FIFO Write pointer
0x08	source_address	R/W	DMA Source Address
0x0c	dma_length	R/W	Length of DMA in bytes
0x10	ahb_conf_reg	R/W	Bits 31..1: reserved Bit 0: Locked AHB Transfers
0x14	fifo_wspace	R/O	Number of Flushed/Discarded fifo bytes
0x18	reserved	R/O	
0x10	full_thresh	R/W	Full Threshold:If bytes stored in FIFO are more than <i>full_thresh</i> , interrupt generation will occur
0x20	empty_thresh	R/W	Empty threshold, if bytes stored in FIFO are less than <i>empty_thresh</i> , interrupt generation will occur
0x24	fifo_rdata	RO	FIFO direct Data Read register

Table 5-2 Register Set (Memory to Bus)

ADDRESS OFFSET	REGISTER		DESCRIPTION
0x00	Control_register	R/W	Bits 31..9: reserved Bit 8: Zero Latency: when set, FIFO read port operates without latency Bit 7: Flush fifo data: set dma length to current fifo size, dma will end when all data are transferred over AHB Bus Bit 6: discard fifo data Bit 5: read fifo reset Bit 4: write fifo read empty flag Bit 1: fifo write full flag Bit 0: dma lock
0x04	fifo_rpointer	RO	FIFO Read pointer
0x08	dest_address	R/W	DMA Destination Address
0x0c	dma_length	R/W	Length of DMA in bytes
0x10	ahb_cont_reg	R/W	Bits 31..1: registered Bit 0: Locked AHB Transfers
0x14	num_of_flushed_bytes	RO	Number of Flushed/Discarded fifo bytes
0x18	reserved		
0x10	full_thresh	R/W	Full threshold: If bytes stored in FIFO are more than <i>full_thresh</i> , interrupt generation will occur
0x20	empty_thresh	R/W	Empty threshold, if bytes stored in FIFO are less, than <i>empty_thresh</i> interrupt will occur
0x24	direct_fifo_read_data	RO	FIFO direct Data Read register

Table 5-2 Register Set (Bus2Bus)

ADDRESS OFFSET	REGISTER		DESCRIPTION
0x00	Control_register	R/W	Bits 31..9: reserved Bit 8: Zero Latency: when set, FIFO read port operates without latency Bit 7: reserved Bit 6: discard fifo data Bit 5: read fifo reset Bit 4: write fifo reset Bit 3: dma start Bit 2: fifo read empty flag Bit 1: fifo write full flag Bit 0: dma lock
0x04	source_address	R/W	DMA Source Address
0x08	dest_address		DMA Destination Address
0x0c	dma_length	R/W	Length of DMA in bytes
0x10	fifo_wpointer	RO	FIFO Write pointer
0x14	fifo_rpointer	RO	FIFO Read pointer
0x18	ahb_conf_reg	R/W	Bits 31..1: Reserved Bit 0: Locked AHB Transfers

0x10	full_thresh	R/W	Full Threshold: If bytes stored in FIFO are more than <i>full_thresh</i> , interrupt generation will occur
0x20	empty_thresh	R/W	Empty threshold, If bytes stored in FIFO are less than <i>empty_thresh</i> , interrupt generation will occur

5 Generator Usage

The DMAC generator employs a graphical web user interface (GUI) for configuring and generating the DMA Controller. In order to use the GUI you must sign-in Think Silicon Ltd web site. If already registered, click on *Sign-in* link in the upper, right side of the web page. Otherwise click on *Register* link first and follow the instructions. The initial GUI page is shown in Figure 4-1.

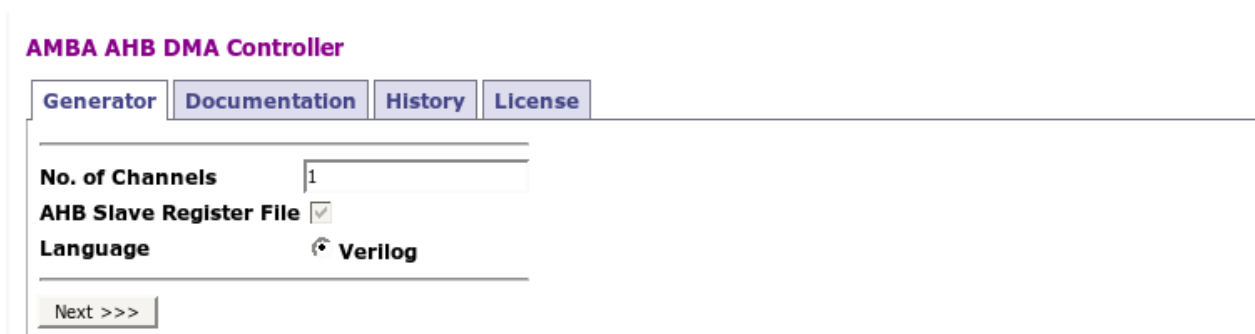

Figure 4-1 AMBA AHB DMA Engine GUI page 1

As depicted in Figure 4-1, the number of supported DMA Channels is configurable. Click *Next* and the second page of DMAC(Figure 4-2.) appears.

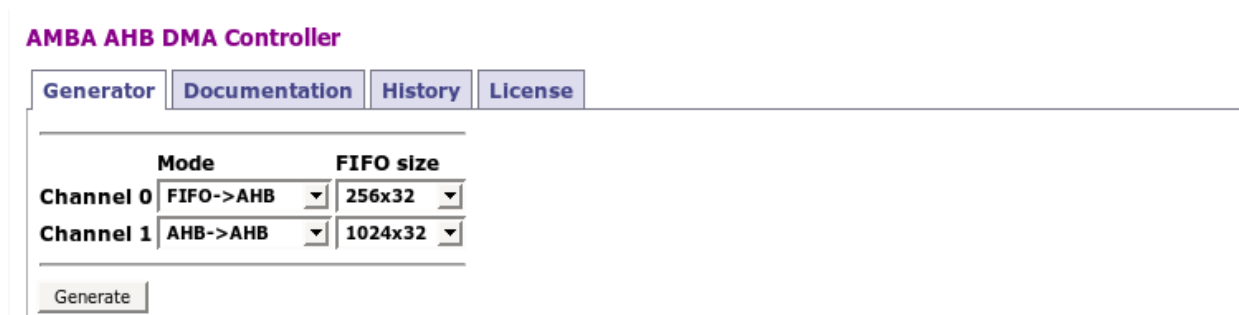

Figure 4-2 AMBA AHB DMA Engine GUI page 2

As shown in Figure 4-2, each channel mode can be selected from following:

- AHB to FIFO : Data transfers from AHB Bus to FIFO, FIFO IF for Data Read
- FIFO to AHB : Data transfers from FIFO to AHB Bus, FIFO IF for Data Write
- AHB to AHB : Data transfers from AHB Bus to AHB Bus
- AHB to different AHB : Data transfers from AHB Bus to different AHB Bus

FIFO size can be selected from the following sizes:

- 128x32, 256x32, 512x32, 1024x32, 2048x32

After having completed the the fields depicted in Figure 4-2, click on the *Generate* button. The generated DMAC package will be sent to the email address given in the registration step.